

# STAGE SET UP

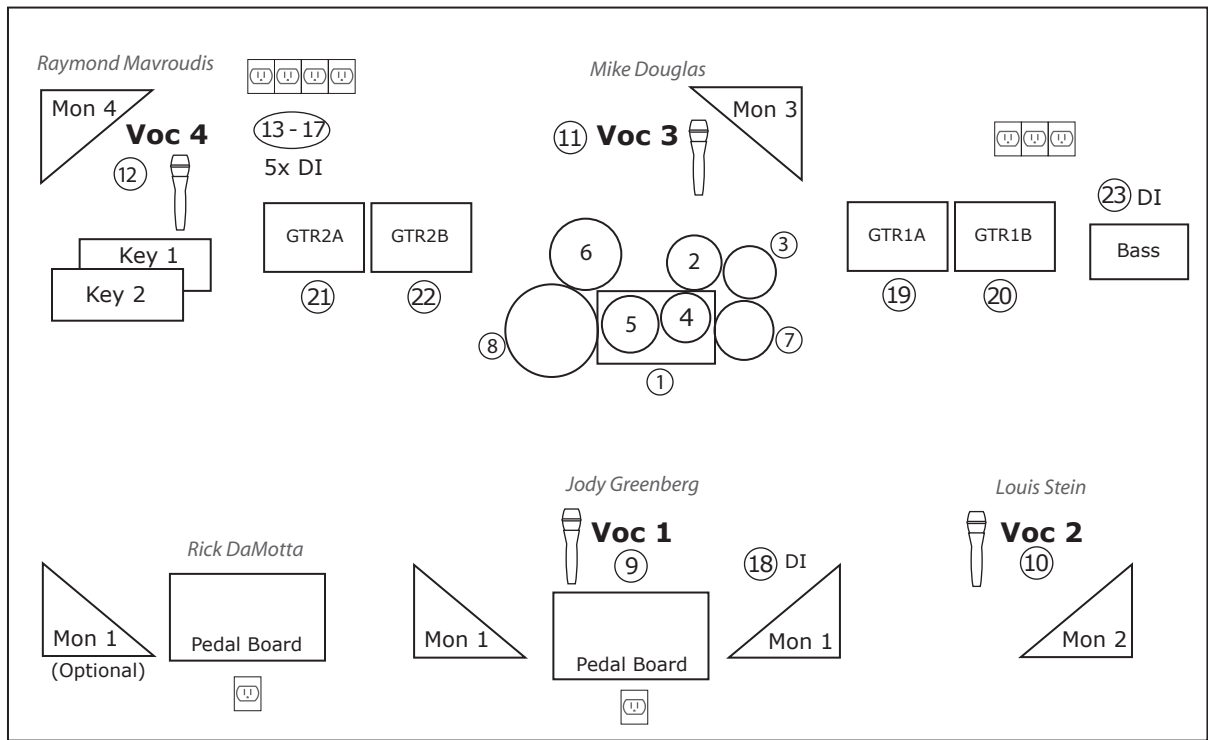

## Inputs

CH	Instrument	Symbol	Mic	Stand	Staging	Insert	Pan	Comments
1	kick	K	beta 52 or equiv.	small boom	U.S.C.	comp1	C	gate1
2	snare	SN	sm57	small boom	U.S.C.	comp2	R10	
3	hi hat	HH	sm57/condenser	boom	U.S.C.		R20	
4	hi tom	T1	senn. 604 or equiv.	claw or boom	U.S.C.	gate2	R10	
5	mid tom	T2	senn. 604 or equiv.	claw or boom	U.S.C.	gate3	L20	
6	floor tom	T3	senn. 604 or equiv.	claw or boom	U.S.C.	gate4	L50	
7	drum OHL	DOHL	sm57/condenser	boom	U.S.C.		R	
8	drum OHR	DOHR	sm57/condenser	boom	U.S.C.		L	optional, one overhead ok
9	lead voc	VoxL	neumann kms-105**	boom	D.S.C.	comp3	C	mic provided
10	bass voc	VoxB	beta58a or equiv.	boom	D.S.L.	comp4	R30	
11	drum voc	VoxD	beta58a or equiv.	boom	U.S.C.	comp5	L20	
12	keys voc	VoxK	beta58a or equiv.	boom	U.S.R.	comp6	L40	for harmonica as well
13	piano L	K1L	active DI		U.S.R.			stereo active DI
14	piano R	K1R	active DI		U.S.R.		C	
15	hammond L	K2L	active DI		U.S.R.			stereo active DI
16	hammond R	K2R	active DI		U.S.R.		L30	
17	ac guitar 2	ACG2	active DI		U.S.R.		L30	
18	ac guitar 1	ACG1	active DI		D.S.C.		C	
19	elec. Guitar 1A	GTR1A	sm57	small boom	U.S.L.		R20	
20	elec. Guitar 1B	GTR1B	sm57	small boom	U.S.L.		R20	blend with GTR1A
21	elec. Guitar 2A	GTR2A	sm57	small boom	U.S.R.		L30	
22	elec. Guitar 2B	GTR2B	sm57	small boom	U.S.R.		L30	blend with GTR2A
23	bass	BASS	DI		U.S.L.	comp7	R10	

\*\* provided by band

## Monitor Mixes

Mix	Contents
1	lead voc, ac guitar 1, elec guitar 1A/B, some drum voc & bass voc & key voc
2	bass voc, some lead voc & drum voc
3	kick, snare, bass, drum voc, some lead & bass voc, some ac guitar 1
4	pianoL/R, hammondL/R, ac guitar 2, key voc, some lead voc & bass voc & drum voc

